

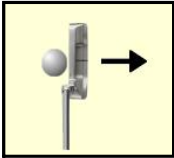

SAM PuttLab

The revolution in short game golf training

Project: European Tour
Player: Lima, Jose Filepe
File: 30.01.2008_01
Date: 30.1.2008



Face at address

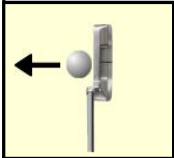
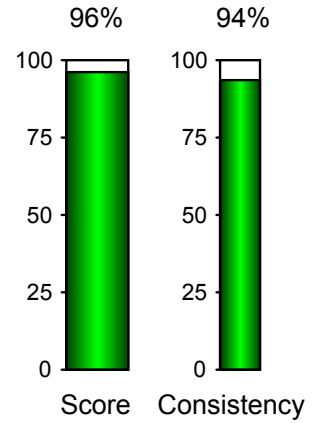
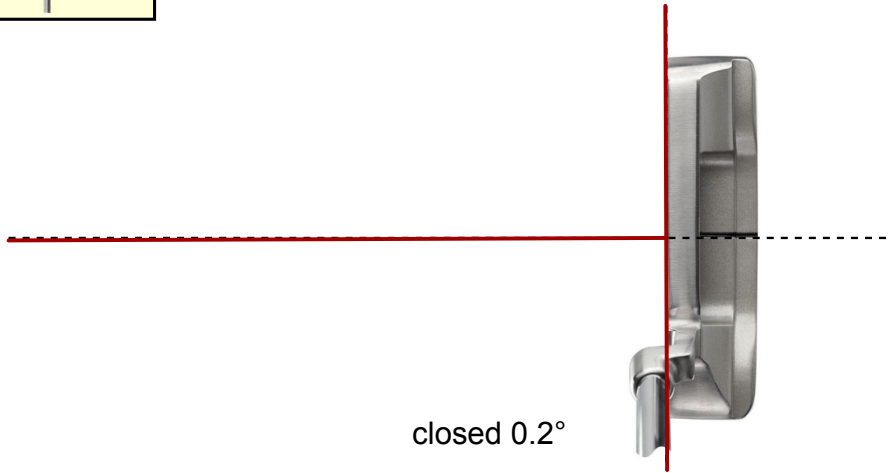

Face at impact

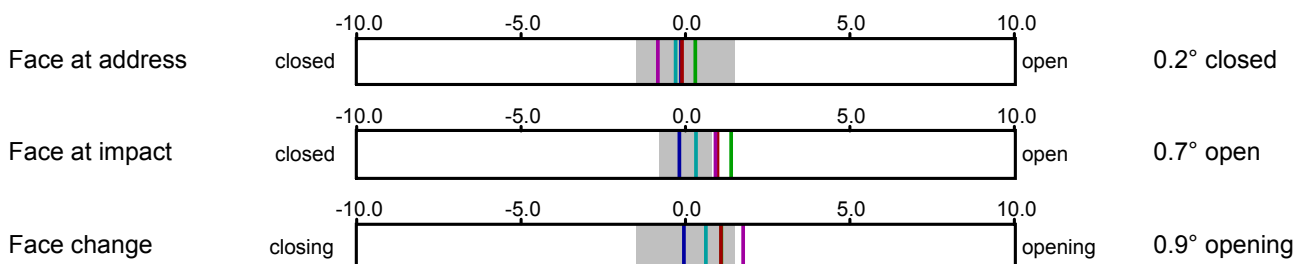
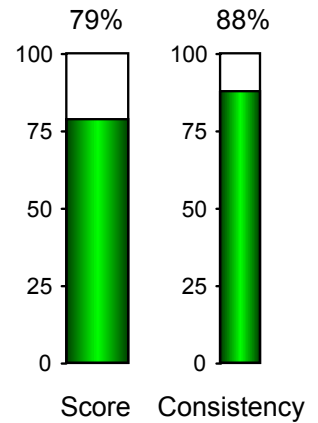
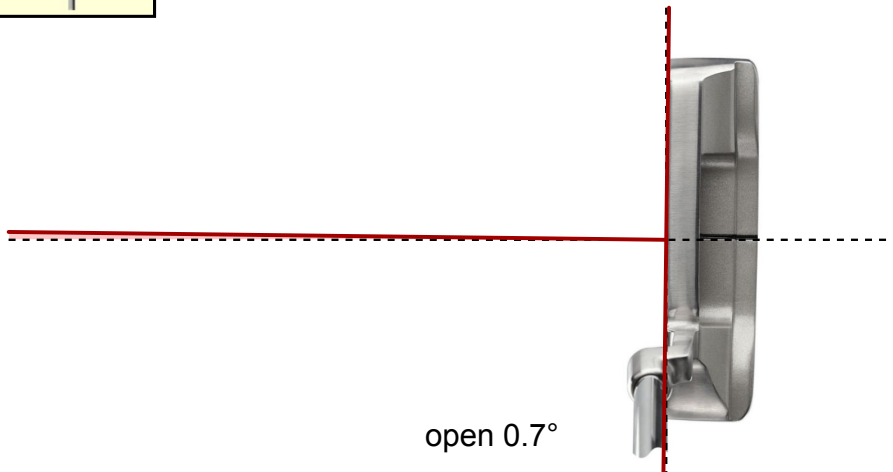



SAM PuttLab

The revolution in short game golf training

Project: European Tour
 Player: Lima, Jose Filepe
 File: 30.01.2008_01
 Date: 30.1.2008

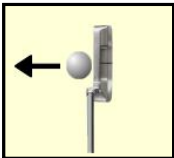

Putter path - top view

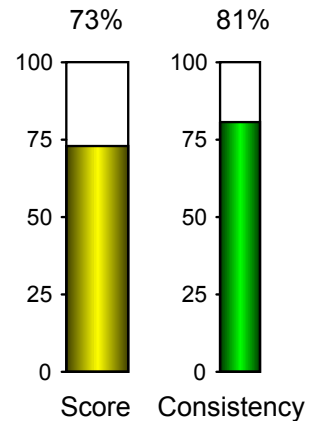
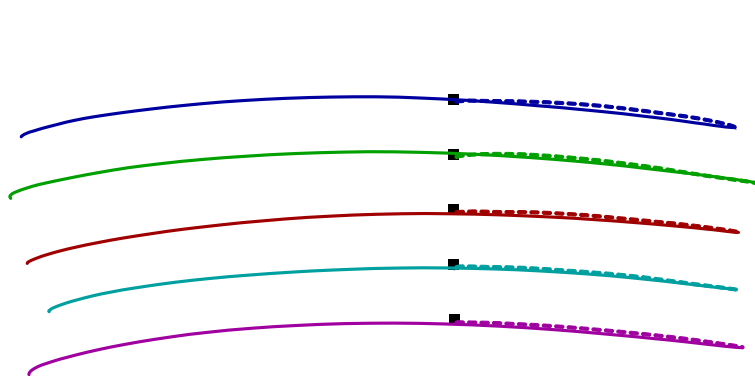

100 mm

2.1° right at impact

Impact spot

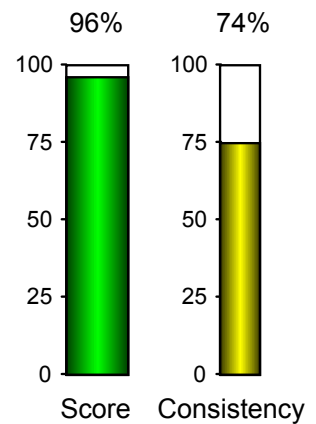
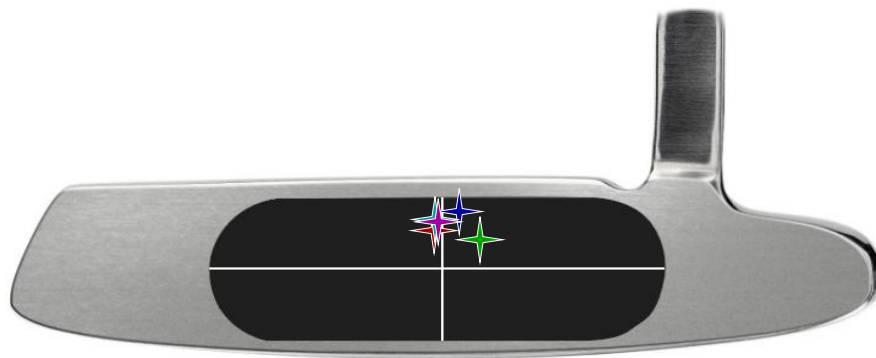

0.6 mm heel

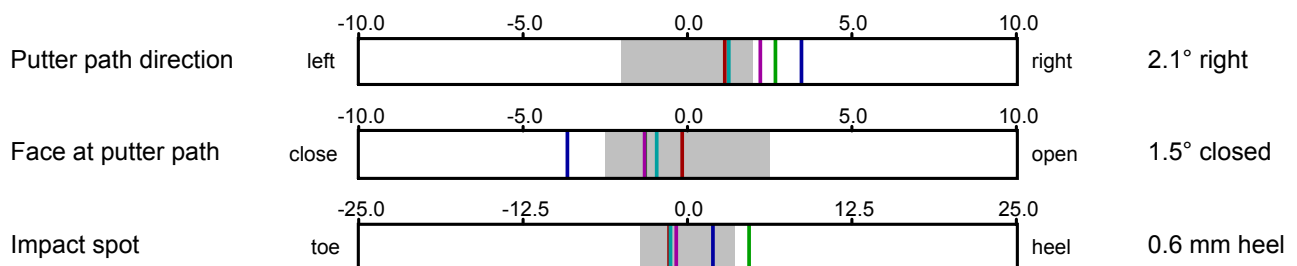



SAM PuttLab

The revolution in short game golf training

Project:	European Tour
Player:	Lima, Jose Filepe
File:	30.01.2008_01
Date:	30.1.2008

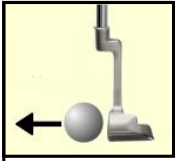

Putter path - side view

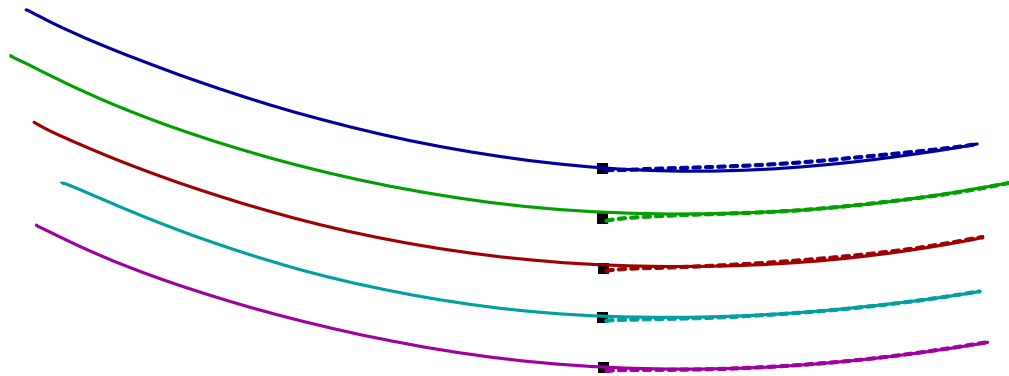

100 mm

3.5° up at impact

Rise & Shaft at impact

Rise angle: 3.5° up

Shaft angle: 0.2° deloft

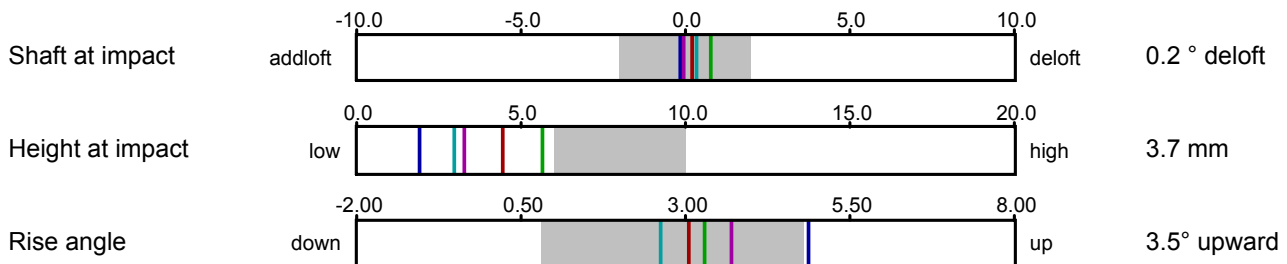
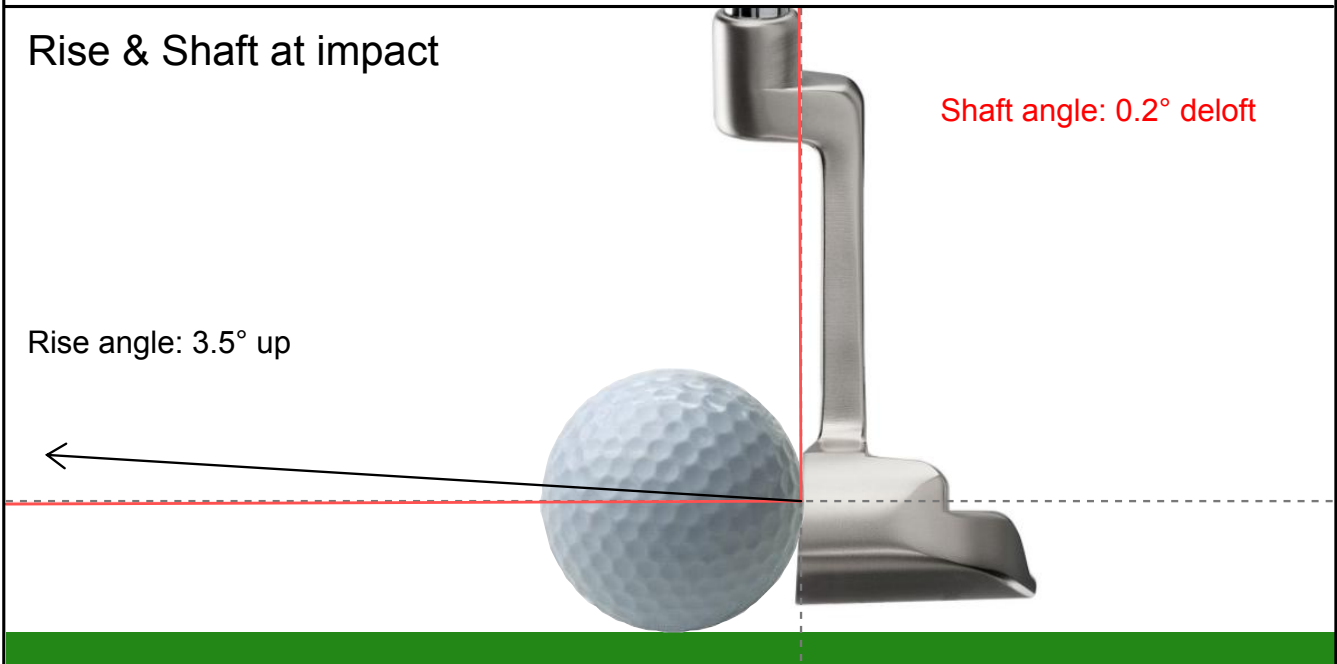



Project: European Tour
Player: Lima, Jose Filepe
File: 30.01.2008_01
Date: 30.1.2008

Clubhead Rotation

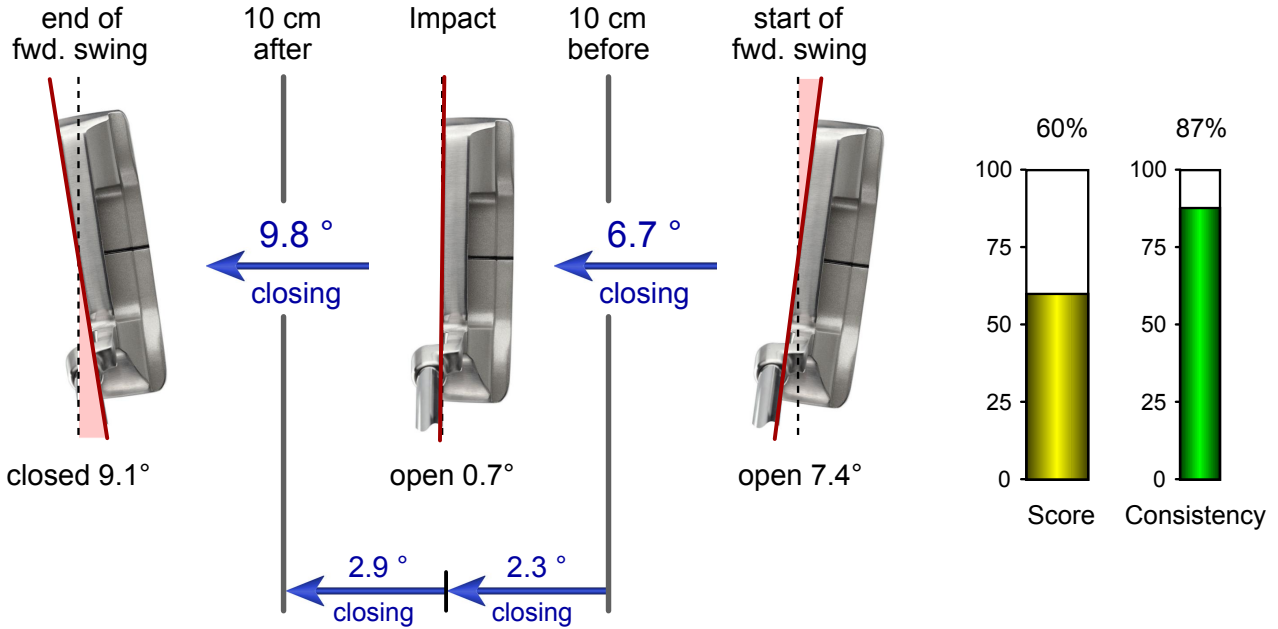

Rotation

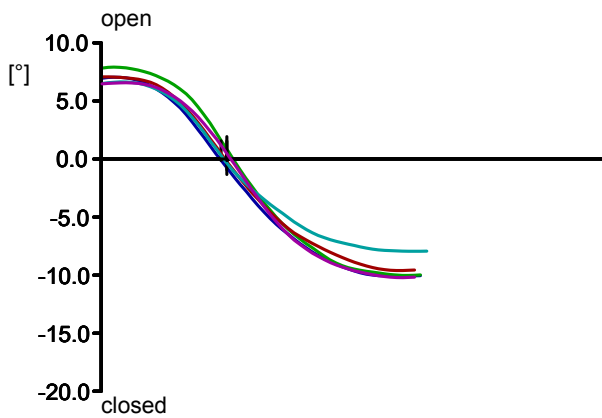

Rate of Rotation

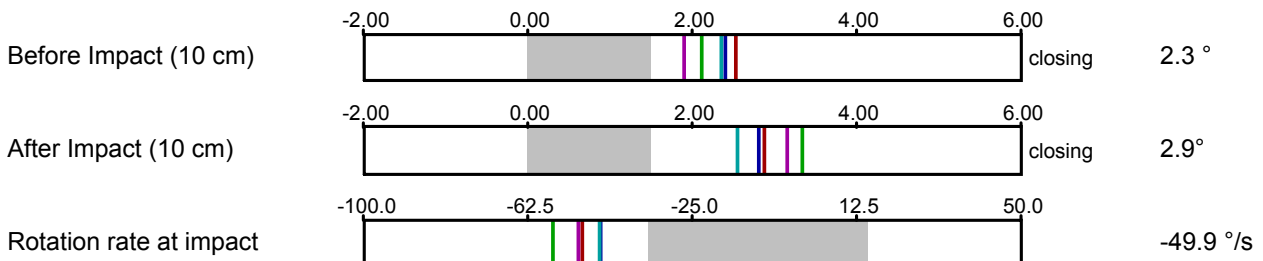
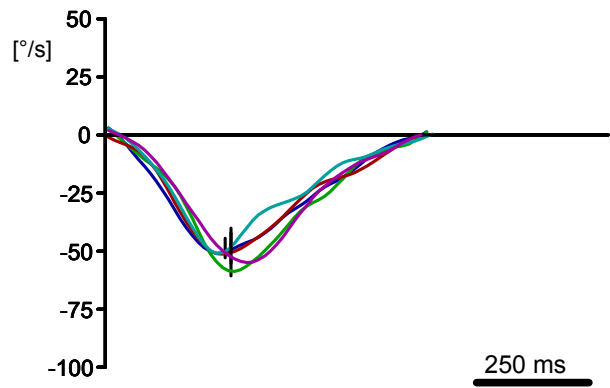



SAM PuttLab

The revolution in short game golf training

Project: European Tour
 Player: Lima, Jose Filepe
 File: 30.01.2008_01
 Date: 30.1.2008

Movement Dynamics

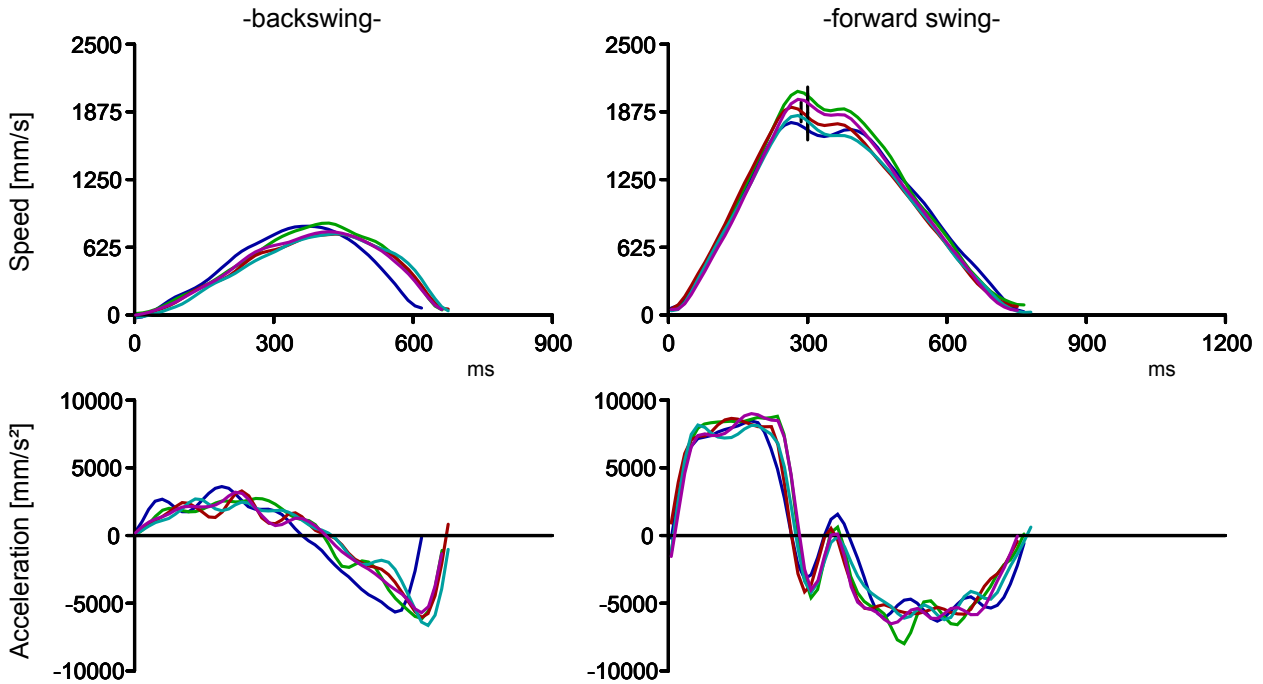

Timing

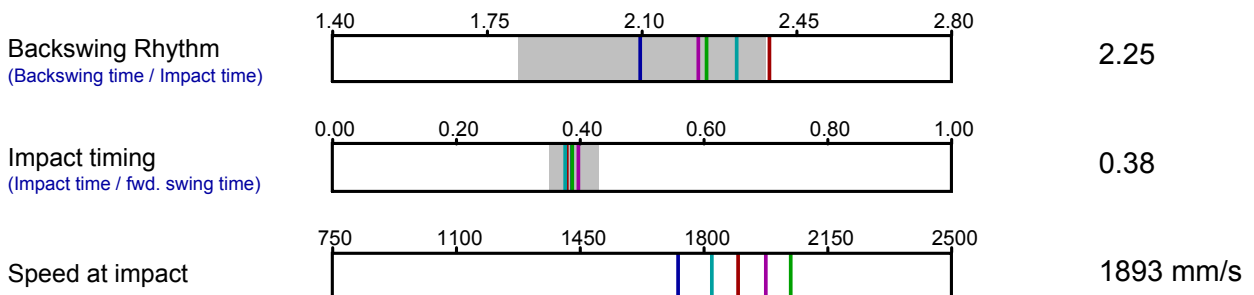
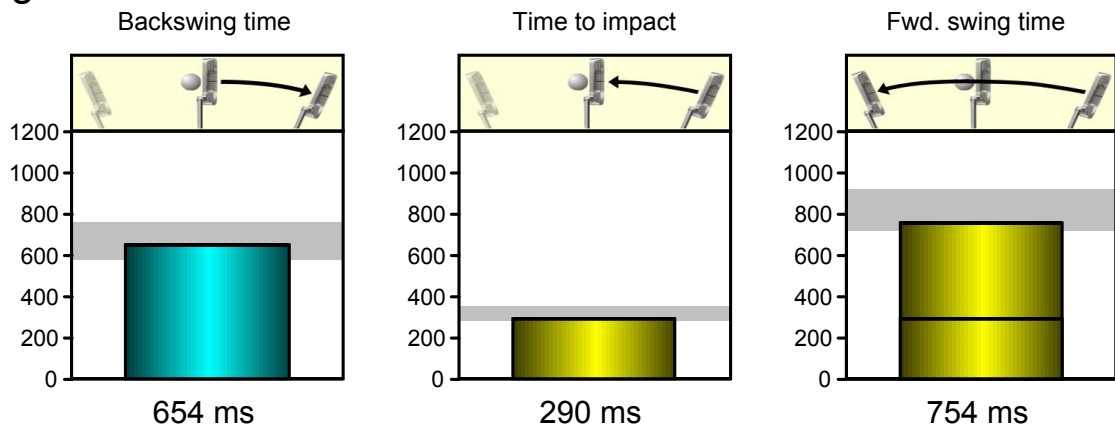



SAM PuttLab
The revolution in short
game golf training

Project:	European Tour
Player:	Lima, Jose Filepe
File:	30.01.2008_01
Date:	30.1.2008

Head Movement

Top view

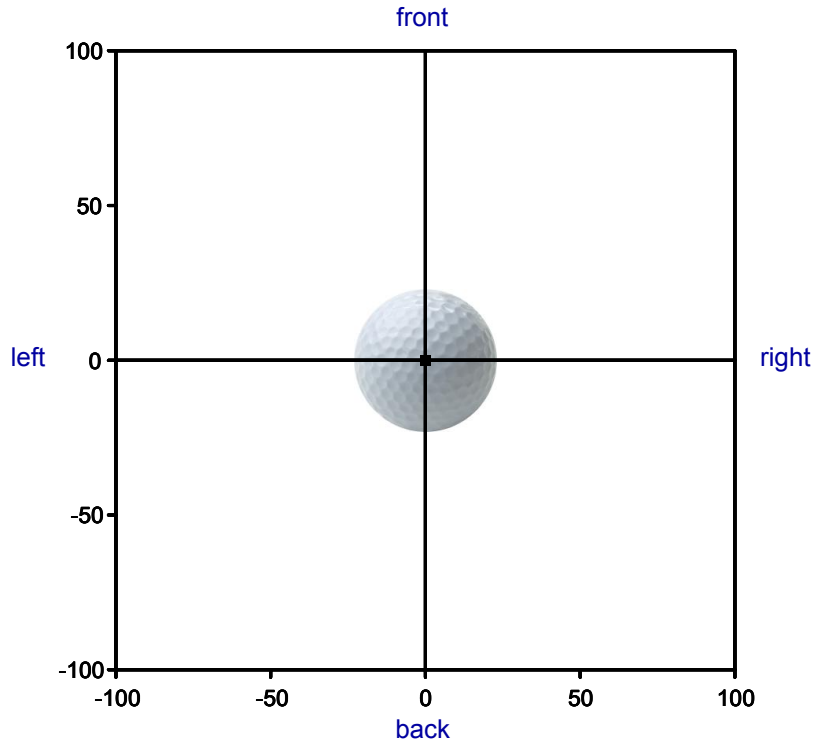
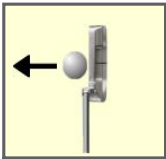

Side view

